

Common Mode Filters

BOK9E SERIES

PRODUCT CATALOG



寶仁弘電子有限公司 Prosperity Electronic Co., Limited

EML: brh@baorenhong.com Web:www.baorenhong.com

TEL: 0755-29687188 FAX: 0755-29688152

深圳市寶安區福永鎮立新二路天佑創客產業園

TEL: 0512-36878535 FAX: 0512-36878435

江蘇省昆山市花橋鎮綠地大道1325號

Common Mode Filters

◎ Product introduction 產品介紹

- Chip common mode filter for large current applications
耐大電流片式共模濾波器
- which are always being made smaller and lighter, because the height has been reduced.
適應小型輕量化的便攜式設備的高密度化趨勢
- Excellent solderability and heat resistance for either flow or reflow soldering
良好的可焊性和耐焊性
- Terminal electrode has been electroplated, suitable flow soldering, reflow soldering an arbitrary welding method
端子電極已經過電鍍，可適用流動焊接，回流焊接任意一種焊接工法

◎ Product application 產品應用

- Power line noise countermeasure for various electronic equipment
應對所有電子設備電源線和噪音
- Noise countermeasure for adapterlines or larger electronic equipment such as note book PCs.
應對筆記本電腦等較大型電子設備適配線的噪音

◎ Product Identification 產品標識

BOK 9E 3A13 T

BOK-----Series name 系列名稱

9E-----Dimension 產品尺寸

3A13-----Product parameters 產品參數 300 Ω/13A

T-----Taping 編帶盤裝

Common Mode Filters

◎Shape&Dimensions 形狀與尺寸:

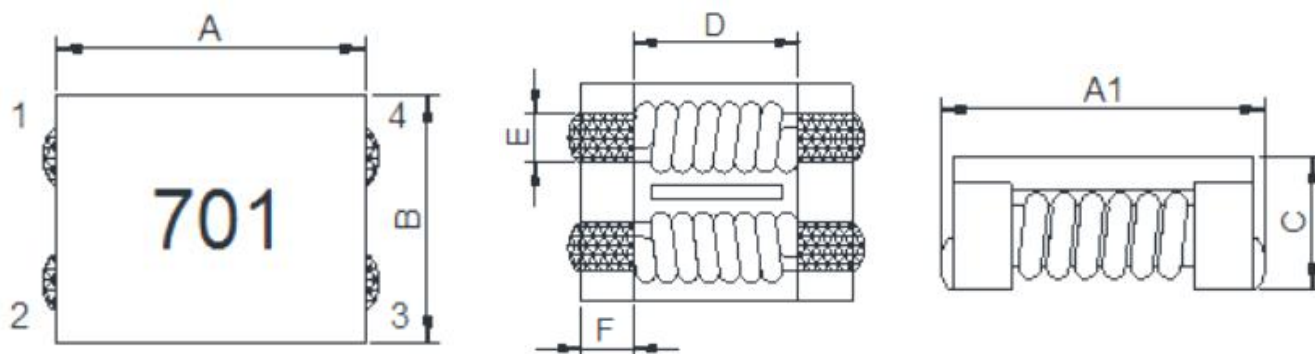

SIZE CODE	A	A1	B	C	D	E	F	MPQ
BOK9E	15.0±0.5	15.3±0.5	13.0±0.5	6.0 Max	9.0 Typ	2.7 Typ	3.0 Typ	0.7 KPCS

◎Circuit Diagram 電路圖

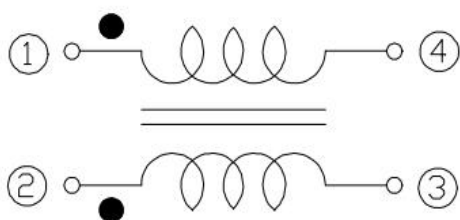

◎Recommender Land Pattern 推薦焊盤布局:

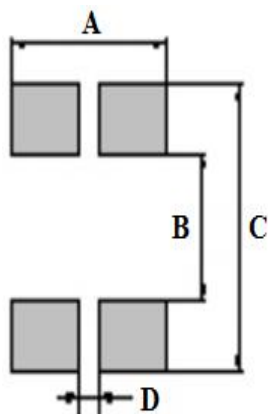

SIZE CODE	A	B	C	D
BOK9E	9.5 Typ	8.0 Typ	16.0 Typ	3.3 Typ

Common Mode Filters

◎ Detailed specifications and parameters are introduced

詳細規格及參數介紹

ORDERING CORE	Impedance(Ω) AT 100MHZ		DC Resistance	Rated Voltage	Insulation Resistance	Rated Current
	Min	Typ	(Ω)MAX /1LINE	(V)MAX	(M Ω)MIN	(mA)MAX
BOK9E-3A13T	250	300	0.0047	80	10	13000
BOK9E-5A10T	450	550	0.0047			10000
BOK9E-6A10T	500	600	0.0070			10000
BOK9E-7A10T	500	700	0.0070			10000
BOK9E-10A10T	800	1000	0.0120			10000

◎ Material List 材料清單

NO.	ITEM	DESCRIPTION	SUPPLIER
1	CORE	FERRITE	FENGYIN OR EQ
2	CASE	LCP/MYLAR	LIAN CHENG OR EQ
3	WIRE	P180 Grd	ELEKTRISOLA OR EQ
4	INK	WHITE	BON MARQUE OR EQ

Common Mode Filters

Operating temperature: -40~+125°C (Including self - temperature rise)

Storage temperature: -40~+125°C (on board)

Item	Performance	Test Condition
Impedance (common mode)	Refer to standard electrical characteristics list.	Agilent-4291A+ Agilent -16197A
DCR		Agilent-4338B
I.R.		Agilent4339
Temperature Rise Test	Rated Current \cong 1A ΔT 40°CMax	1.Applied the allowed DC current. 2.Temperature measured by digital surface thermometer

Common Mode Filters

Impedance:

Measured by using HP4291B RF Impedance Analyzer.

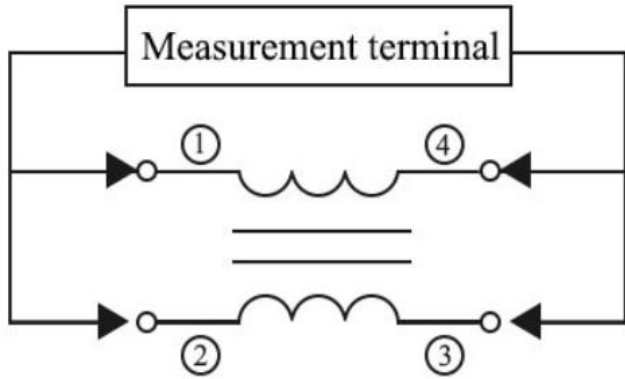

DC Resistance:

Measured by using Chroma 16502 milliohm meter.

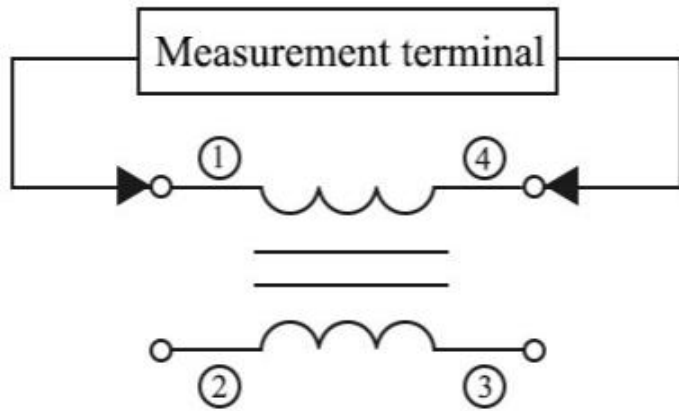

Insulation Resistance:

Measured by using Chroma 19073.

Measurement voltage : 50v , Measurement time : 60 sec.

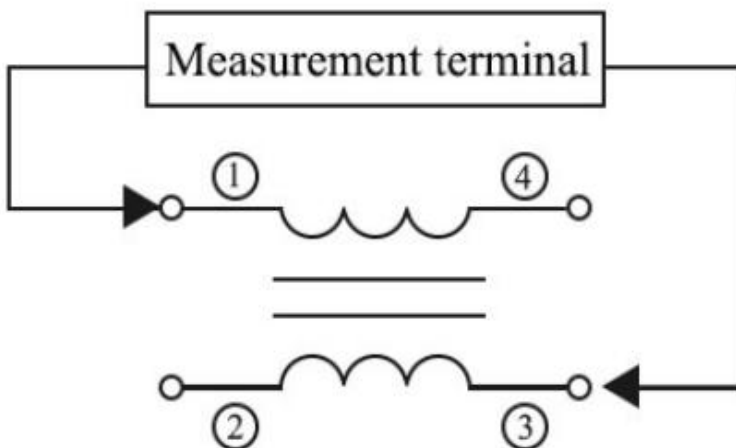

Common Mode Filters

Item	Performance	Test Condition
Life Test	Appearance: No damage. Impedance: within±25% of initial value Inductance: within±15% of initial value Q: Shall not exceed the specification value. RDC: within ±15% of initial value and shall not exceed the specification value	Preconditioning: Run through IR reflow for 2 times. (IPC/JEDEC J-STD-020DClassification Reflow Profiles) Temperature: 125±2°C Applied current: rated current Duration: 1000±12hrs Measured at room temperature after placing for 24±2 hrs
Load Humidity		Preconditioning: Run through IR reflow for 2 times. (IPC/JEDEC J-STD-020DClassification Reflow Profiles) Humidity: 85±2 % R.H, Temperature: 85°C±2°C Duration: 1000hrs Min. with 100% rated current Measured at room temperature after placing for 24±2 hrs
Moisture Resistance		Preconditioning: Run through IR reflow for 2 times. (IPC/JEDEC J-STD-020DClassification Reflow) . Profiles 1. Baked at50°C for 25hrs, measured at room temperature after placing for 4 hrs. 2. Raise temperature to 65±2°C 90-100%RH in 2.5hrs, and keep 3 hours, cool down to 25°C in 2.5hrs. 3. Raise temperature to 65±2°C 90-100%RH in 2.5hrs, and keep 3 hours, cool down to 25°C in 2.5hrs,keep at 25 °C for 2 hrs then keep at -10°C for 3 hrs 4. Keep at 25°C 80-100%RH for 15min and vibrate at the frequency of 10 to 55 Hz to 10 Hz, measure at room temperature after placing for 1~2 hrs.
Thermal shock		Preconditioning: Run through IR reflow for 2 times. (IPC/JEDEC J-STD-020DClassification) Reflow Profiles Condition for 1 cycle Step1: -40±2°C 30±5min Step2: 25±2°C ≤0.5min Step3: 125±2°C 30±5min Number of cycles: 500 Measured at room temperature after placing for 24±2 hrs
Vibration		Oscillation Frequency: 10~2K~10Hz for 20 minutes Equipment: Vibration checker Total Amplitude:1.52mm±10% Testing Time : 12 hours(20 minutes, 12 cycles each of 3 orientations)。

Common Mode Filters

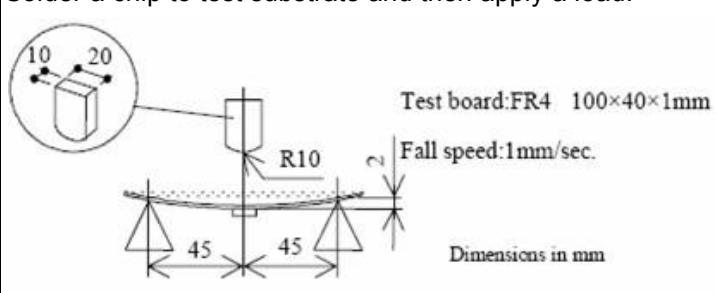
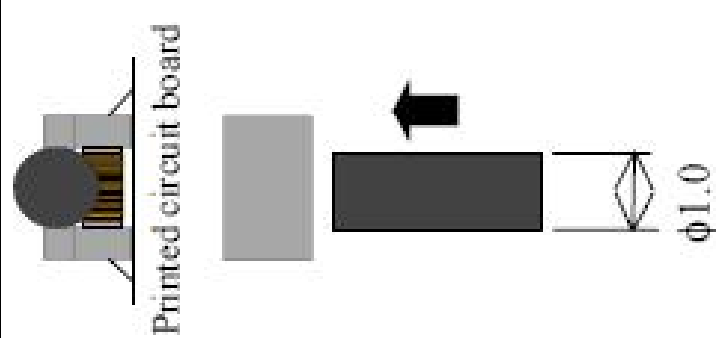
Item	Performance	Test Condition															
Strength on PC board bending	Appearance: No damage. Impedance: within±25% of initial value Inductance: within±15% of initial value Q: Shall not exceed the specification value. RDC: within ±15% of initial value and shall not exceed the specification value.	Solder a chip to test substrate and then apply a load. 															
Shock	The terminal electrode and the ferrite must not be damaged.	<table border="1" style="width: 100%; border-collapse: collapse; text-align: center;"> <thead> <tr> <th>Type</th> <th>Peak value (g's)</th> <th>Normal duration (D) (ms)</th> <th>Wave form</th> <th>Velocity change (Vi)ft/sec</th> </tr> </thead> <tbody> <tr> <td>SMD</td> <td>50</td> <td>11</td> <td>Half-sine</td> <td>11.3</td> </tr> <tr> <td>Lead</td> <td>50</td> <td>11</td> <td>Half-sine</td> <td>11.3</td> </tr> </tbody> </table>	Type	Peak value (g's)	Normal duration (D) (ms)	Wave form	Velocity change (Vi)ft/sec	SMD	50	11	Half-sine	11.3	Lead	50	11	Half-sine	11.3
Type	Peak value (g's)	Normal duration (D) (ms)	Wave form	Velocity change (Vi)ft/sec													
SMD	50	11	Half-sine	11.3													
Lead	50	11	Half-sine	11.3													
Solder ability	More than 95% of the terminal electrode should be covered with solder. The product shall be connected to the test circuit board by the fillet (the height is 0.2mm).	Preheat: 150℃,60sec. Solder: Sn96.5% Ag3% Cu0.5% Temperature: 245±5℃。 Flux for lead free: Rosin. 9.5%。 Dip time: 4±1sec。 Depth: completely cover the termination															
Resistance to Soldering Heat	Appearance: No damage. Impedance: within±25% of initial value	Depth: completely cover the termination <table border="1" style="width: 100%; border-collapse: collapse; text-align: center;"> <thead> <tr> <th>Temperature (°C)</th> <th>Time(s)</th> <th>Temperature ramp/immersion and emersion rate</th> <th>Number of heat cycles</th> </tr> </thead> <tbody> <tr> <td>260 ±5 (solder temp)</td> <td>10 ±1</td> <td>25mm/s ±6 mm/s</td> <td>1</td> </tr> </tbody> </table>	Temperature (°C)	Time(s)	Temperature ramp/immersion and emersion rate	Number of heat cycles	260 ±5 (solder temp)	10 ±1	25mm/s ±6 mm/s	1							
Temperature (°C)	Time(s)	Temperature ramp/immersion and emersion rate	Number of heat cycles														
260 ±5 (solder temp)	10 ±1	25mm/s ±6 mm/s	1														
Terminal Strength	Inductance: within±15% of initial value Q: Shall not exceed the specification value. RDC: within ±15% of initial value and shall not exceed the specification value. The terminal electrode and the ferrite must not be damaged.	Solder a chip to test substrate , and then laterally apply a load 9.8N in the arrow direction. 															

Common Mode Filters

- Mildly activated rosin fluxes are preferred. If hand soldering cannot be avoided, the preferred technique is the utilization of hot air soldering tools.

1. Recommended temperature profiles for re-flow soldering

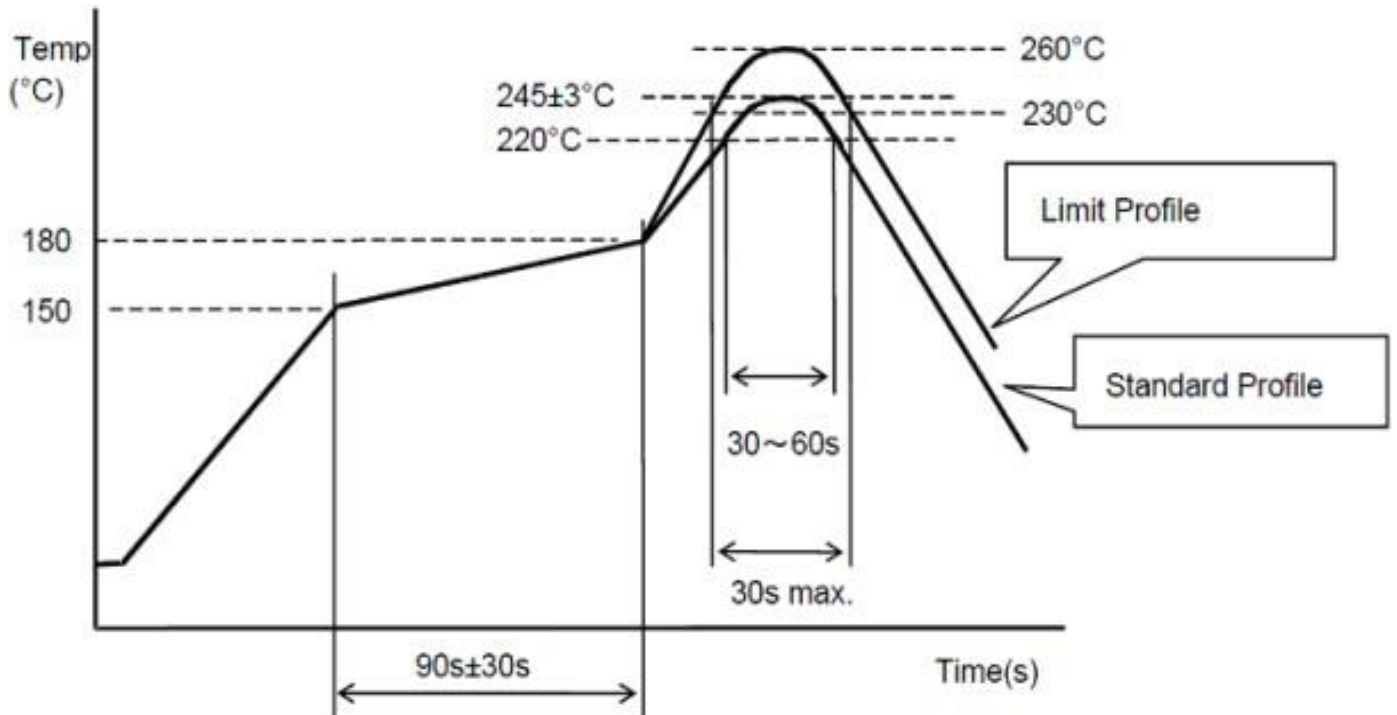

	Standard Profile	Limit Profile
Pre-heating	150~180°C , 90s±30s	
Heating	above 220°C, 30s~60s	above 240°C, 30s max.
Peak temperature	245±3°C	260°C, 10s
Cycle of reflow	2 times	2 times

2. Flux, Solder

- Use rosin-based flux
- Don't use high acidic flux with halide content exceeding 0.2(wt)% (chlorine conversion value).
- Use lead-free solder, use Sn-3.0Ag-0.5Cu solder
- Standard thickness of solder paste: 0.12~0.15mm

3. Reworking with soldering iron

The following conditions must be strictly followed when using a soldering iron.

Pre - heating	150°C, 1 minute
Tip temperature	350°C max.
Soldering iron output	30w max.
End of soldering iron	φ 3mm max.
Soldering time	3 seconds max.

Common Mode Filters

• **Products should be cleaned on the following conditions.**

Cleaning temperature shall be limited to 60°C max. (40°C max for fluoride and alcohol type cleaner.)

Ultrasonic cleaning shall comply with the following conditions with avoiding the resonance phenomenon at the mounted products and P.C.B.

Power: 20 w / liter max.

Frequency: 28 kHz ~ 40 kHz

Time: 5 minutes max.

Cleaner

☉Alcohol cleaner • Isopropyl alcohol (IPA)

☉Aqueous agent • PINE ALPHA ST – 100S

Cleaning Conditions:

Do not clean after soldering. Some cleaning agents may degrade bonding strength, and characteristics of products by detaching. If cleaning, please contact us.

There shall be no residual flux and residual cleaner after cleaning, extra flux maybe affect the electrical characteristics. In the case of using aqueous agent, products shall be dried completely after rinse with de-ionized water in order to remove the cleaner.

Common Mode Filters

The impedance value may change due to high cure-stress of resin to be used for coating/molding products. An open circuit issue may occur by mechanical stress caused by the resin, amount/cured shape of resin, or operating condition etc. Some resin contains some impurities or chloride possible to generate chlorine by hydrolysis under some operating condition may cause corrosion of wire of coil, leading to open circuit. So, please pay your careful attention in selecting resin in case of coating/molding the products with the resin. Prior to use the coating resin, please make sure no reliability issue is observed by evaluating products mounted on your board.

Common Mode Filters

<Exclusive use of Reflow soldering> Flow soldering may cause deterioration in insulation resistance.

So, reflow soldering shall be applied for this product.

Common Mode Filters

The following shall be considered when designing and laying out P.C.B.

P.C.B shall be designed so that products are not subjected to the mechanical stress due to warping the board.

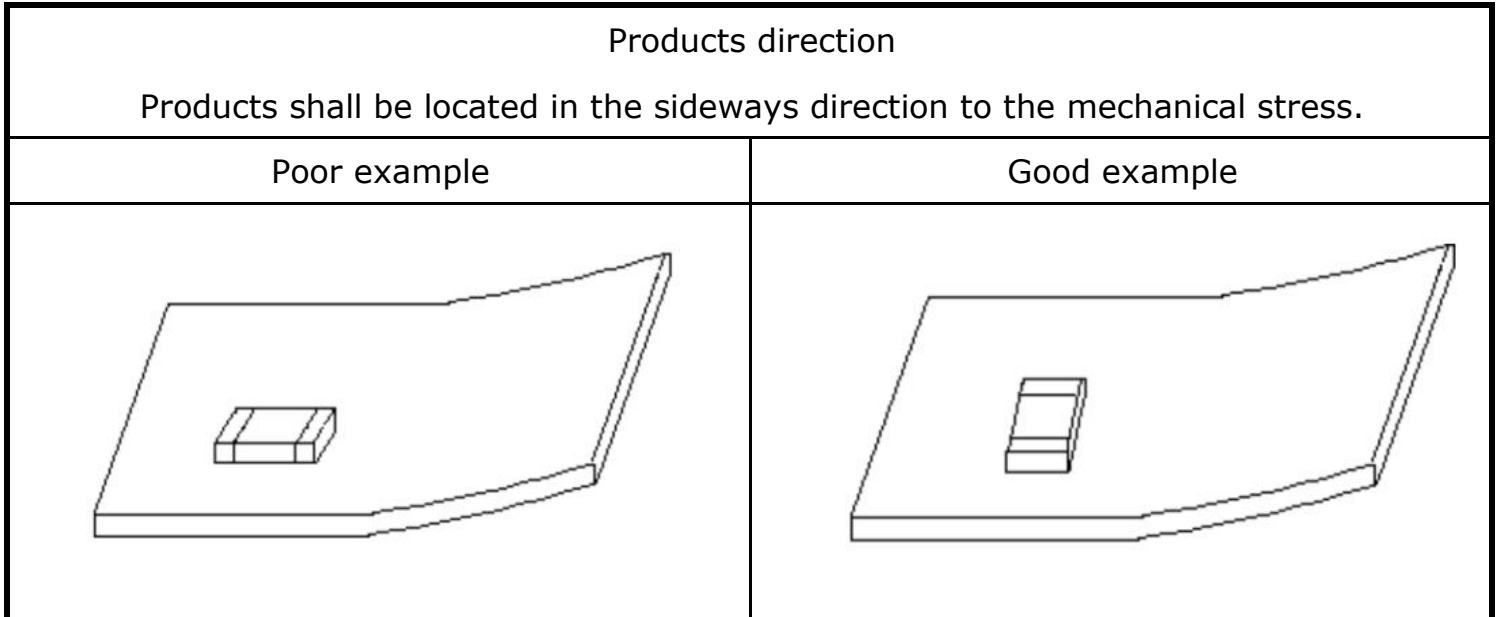

Products location on P.C.B. separation.

Products shall be located carefully so that products are not subjected to the mechanical stress due to warping the board. Because they may be subjected the mechanical stress in magnitude of $A > C > B \approx D$.

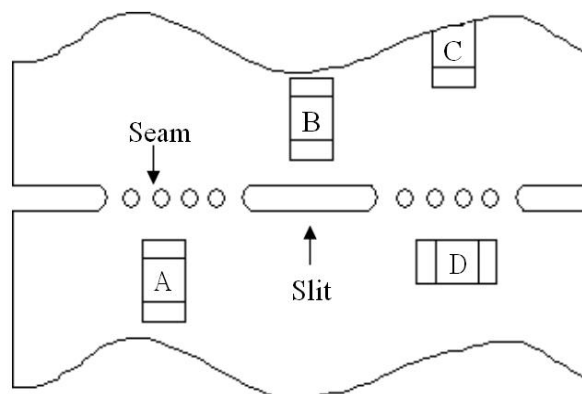

Common Mode Filters

The electrical characteristics may be changed due to the large cure-stress of the resin to be used for coating/molding products. Some resin contains some impurities or chloride possible to generate chlorine by hydrolysis under some operating condition may cause corrosion of wire of coil ,leading to open circuit. So please pay your careful attention in selecting resin to prevent any affection on the product in case of coating/molding the products with the resin. In prior to use,please make the reliability evaluation with the product mounted in your application set.

Common Mode Filters

Limitation of Applications

Please contact us before using our products for the applications listed below which require especially high reliability for the prevention of defects which might directly cause damage to the third party's life, body or property.

1. Aircraft equipment
2. Aerospace equipment
3. Undersea equipment
4. Power plant control equipment
5. Medical equipment

Requirements to the applications listed in the above.

6. Transportation equipment (vehicles, trains, ships, etc.)
7. Traffic signal equipment
8. Disaster prevention / crime prevention equipment
9. Data-processing equipment
10. Applications of similar complexity and / or reliability

There is possibility that the inductance value change due to magnetism. Don't use a magnet or a pair of tweezers with magnetism when chip coil are handled. (The tip of the tweezers should be molded with resin or pottery.)

Sharp material, such as a pair of tweezers, shall not be touched to the winding portion to prevent the breaking of wire.

Mechanical shock should not be applied to the products mounted on the board to prevent the breaking of the core.

Common Mode Filters

Storage period

Products should be used in 6 months from the day of PROSPERITY ELECTRONICS CO.,LTD outgoing inspection. Solderability should be checked if this period is exceeded.

Storage conditions

Products should be storage in the warehouse on the following conditions.

Temperature : 0 ~ 40°C

Humidity : 55 ~ 70% relative humidity

No rapid change on temperature and humidity

Don't keep products in corrosive gases such as sulfur, chlorine gas or acid, or it may cause oxidation of electrode, resulting in poor solderability.

Products should be stored on the palette for the prevention of the influence from humidity, dust and so on.

Products should be stored in the warehouse without heat shock, vibration, direct sunlight etc.

Products should be stored under the airtight package condition.

Handling Condition

Care should be taken when transporting of handling product to avoid excessive vibration or mechanical shock.

Common Mode Filters

◆ Tape Dimensions And Packaging Quantities :

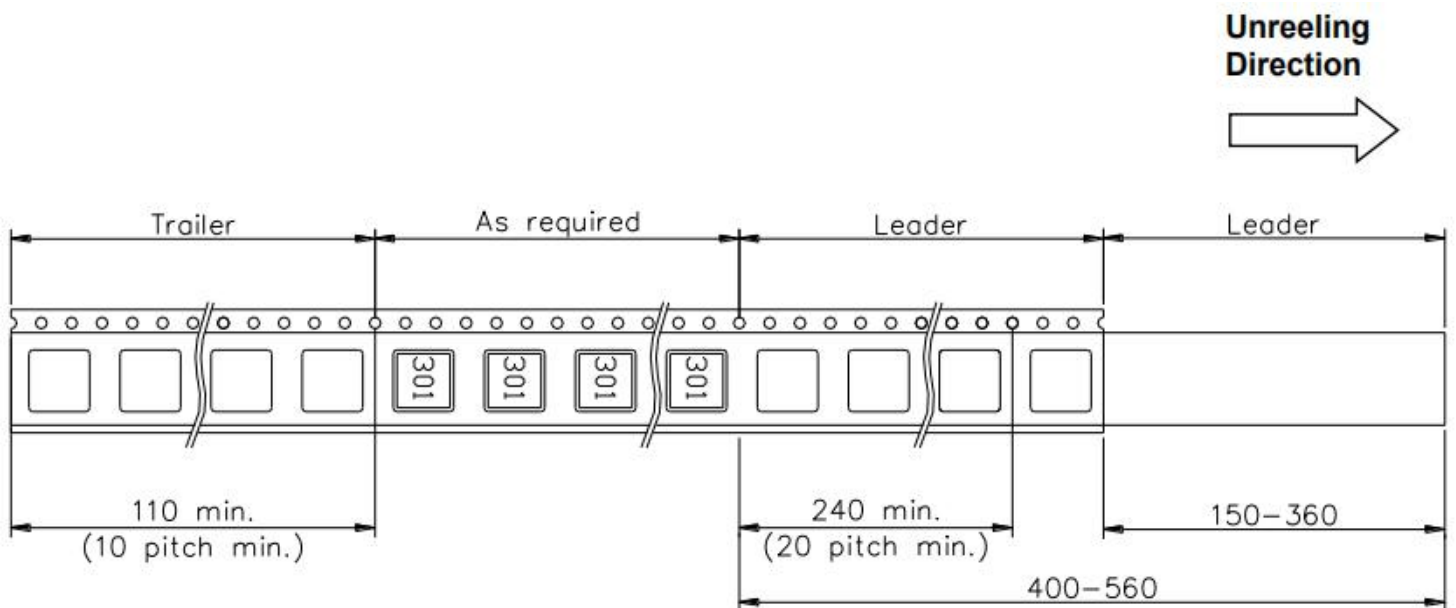
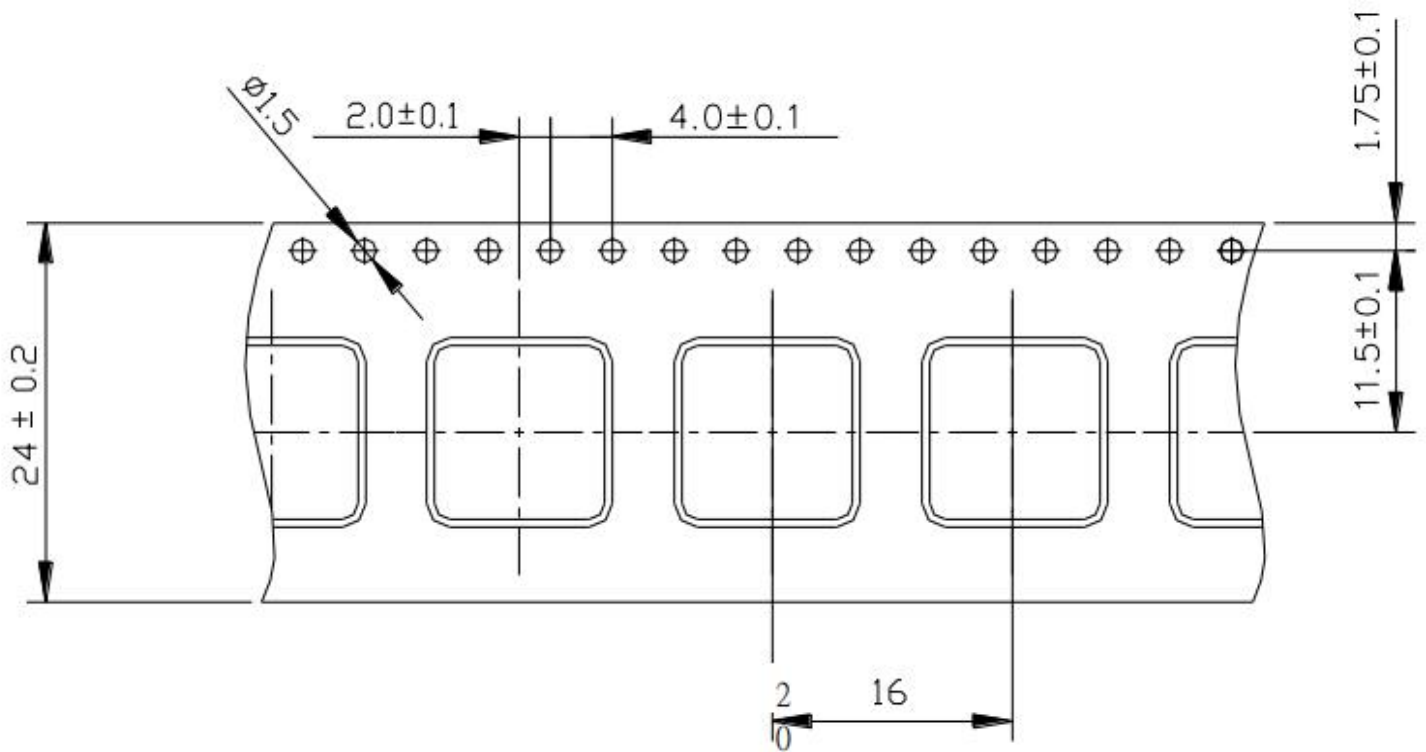

Common Mode Filters

◆ Tape Dimensions And Packaging Quantities :

The force for tearing off cover tape is 15 to 130 grams in the arrow direction

